



Welcome to the Methodist Church's
campaign for Lent and Easter 2025

Worship Resource Pack

In the wilderness, Jesus reminded us that people don't live by bread alone. Through these worship plans we'll explore together what sustains and nourishes us – both food and beyond.

The 1999 Conference report *Called to Love and Praise* describes the vision for a vibrant church community, highlighting qualities like:

- A community nourished by powerful songs of faith, prayers that draw from rich Christian tradition and modern life, and preaching that speaks meaningfully to today's world with depth and integrity.
- A place of warm fellowship, a "home away from home", committed to justice, peace and forgiveness.

Weekly offer

Each week, we'll reflect on what sustains us based on the lectionary Gospel passage for Sunday. There will be an email sent out each day. Here's what to expect in your inbox each day if you sign up for emails at methodist.org.uk/SoulFood.

Monday

A recipe video using easily available ingredients. We encourage you to cook and share this with your community – perhaps as a Sunday meal after church!

Tuesday

A Bible study video, with discussion on questions from the week's Gospel passage.

Wednesday

A craft video, perfect for doing at home or in a group setting.

Thursday

An inspiring story about how the Methodist Church and our partners work to ensure nourishment and care for all.

Friday

A reflection on a classic soul song, revealing the good news within its lyrics.

Saturday

Soul Food Saturday, our magazine-style video show, featuring a panel sharing weekly highlights and showcasing photos from across the Church. We'd love to see what you're up to during Lent!

Sunday

No email, but we invite you to gather in worship, reflecting on the theme as you praise God together.

Service outline guide

Each outline in this pack provides a range of ideas as a flexible 'menu' to help you shape a service that fits your unique context, whether you're meeting in a chapel, school assembly, chaplaincy hub, care home, or elsewhere. There's no need to use everything provided – feel free to select what suits best.

Key elements

Theme and scripture

Passages are drawn from the lectionary and quoted from the New Revised Standard Version Updated Edition.

Songs and hymns

Additional song suggestions complement *Singing the Faith* recommendations, drawing from its full contents and the Resources Hub.

Opening liturgy

Includes words for reflection and an object to place around a Lenten cross, thanks to the Revd Elaine Halls. The complete liturgy is available as a separate PDF, ideal for printing and distributing.

Background notes

Brief contextual notes for each service, connecting the theme with selected Bible passages. This year, we've deepened the exegesis as requested in your feedback. Feel free to draw from these as needed, though they're not designed to be read out as a sermon.

Questions

These can serve as sermon points or discussion prompts, encouraging the congregation to explore their faith. They also work well in small group settings.

Good news to get across

A central message for newcomers, with a connected Methodist Way of Life commitment. Repeat it often to make it memorable!

Prayer ideas

Creative options for incorporating prayer into the service.

Hands-on activities

Intergenerational activities to engage all ages and make your service interactive. With a few adjustments, these activities can also be used with online groups.

Ways people can respond

Simple, accessible ways for individuals to respond personally to the message.

Prayer of blessing

A closing blessing to end the service with encouragement and grace.



	DATE	WEEKLY THEME	OLD TESTAMENT	NEW TESTAMENT
LENT 1	9/3/25	Soul Food: All the things that nourish us	Psalms 91:1-2, 9-16	Luke 4:1-13
LENT 2	16/3/25	Soul Shelter: Nourished by a safe home (for everyone)	Psalms 27	Luke 13:31-35
LENT 3	23/3/25	Soul Rest: Nourished by patience and slowness	Psalms 63:1-8	Luke 13:1-9
LENT 4	30/3/25	Soul Repair: Nourished by unconditional love and forgiveness (Mothering Sunday)	Psalms 32	Luke 15:1-3, 11b-32
LENT 5	6/4/25	Soul Mates: Nourished by companionship	Psalms 126	John 12:1-8
PALM SUNDAY	13/4/25	Soul Songs: Nourished by music from the heart	Psalms 118:1-2, 19-29	Luke 19:28-40
GOOD FRIDAY	18/4/25	Soul Support: Nourished by each other when times are tough	Psalms 22	John 19:13-42
EASTER DAY	20/4/25	Soul Stories: So well nourished that we have to share it	Psalms 118:1-2, 14-24	Luke 24:1-12

Sunday 9 March 2025

Lent 1: Soul Food

All the things that nourish us

Bible readings

Psalm 91:1-2, 9-16

You who live in the shelter of the Most High,
who abide in the shadow of the Almighty,
will say to the LORD, "My refuge and my
fortress;

my God, in whom I trust."

Because you have made the LORD your
refuge,

the Most High your dwelling place,
no evil shall befall you,

no scourge come near your tent.

For he will command his angels concerning
you

to guard you in all your ways.

On their hands they will bear you up,

so that you will not dash your foot against a
stone.

You will tread on the lion and the adder;

the young lion and the serpent you will
trample under foot.

Those who love me, I will deliver;

I will protect those who know my name.

When they call to me, I will answer them;

I will be with them in trouble;

I will rescue them and honour them.

With long life I will satisfy them

and show them my salvation.

Luke 4:1-13

Jesus, full of the Holy Spirit, returned from
the Jordan and was **led by the Spirit in the
wilderness**, where for **forty days** he was
tested by the devil. He ate nothing at all

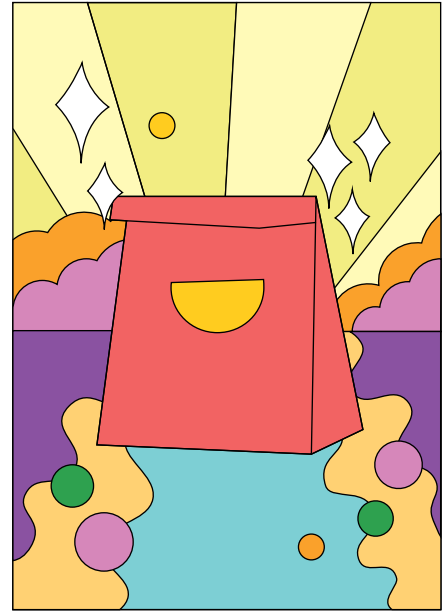

during those days, and when they were over
he was famished. The devil said to him, "If
you are the Son of God, command this stone
to become a loaf of bread." Jesus answered
him, "It is written, '**One does not live by bread
alone.**' "

Then the devil led him up and showed him in
an instant all the kingdoms of the world. And
the devil said to him, "To you I will give all this
authority and their glory, for it has been given
over to me, and I give it to anyone I please. If
you, then, will worship me, it will all be yours."
Jesus answered him, "It is written,

**'Worship the Lord your God, and serve only
him.'** "

Then the devil led him to Jerusalem and
placed him on the pinnacle of the temple and
said to him, "If you are the Son of God, throw
yourself down from here, for it is written,

'He will command his angels concerning you,
to protect you,'

and

'On their hands they will bear you up,
so that you will not dash your foot against a
stone.'

Jesus answered him, "It is said, '**Do not put the
Lord your God to the test.**' " When the devil had
finished every test, he departed from him until
an opportune time.

Songs and hymns

- Alleluia! Sing to Jesus (StF 568)
- As the glory of creation and the thrill of human love (StF 725)
- Christ our Redeemer knew temptation's hour (StF 235)
- Jesus tempted in the desert (StF 237)
- Now thank we all our God (StF 81)
- The earth is the Lord's (Mission Praise 642 / Songs of Fellowship 528)
- **Wake, O my soul, to earth and sea and sky** (website only)

Opening liturgy

Give us this day our daily bread to feed our soul.
We don't need distractions of a glitzy package,
a brown paper bag does just fine.

Give us this day our daily bread to feed our soul.
To nourish our minds and warm our hearts,
to enrich our faith, our belief, our life...

Give us this day our daily bread to feed our soul.
Let us never forget you are our God,
the giver of love and joy and hope.

O Lord our God, on this Lenten journey,
feed our souls this day we pray. Amen.

Object

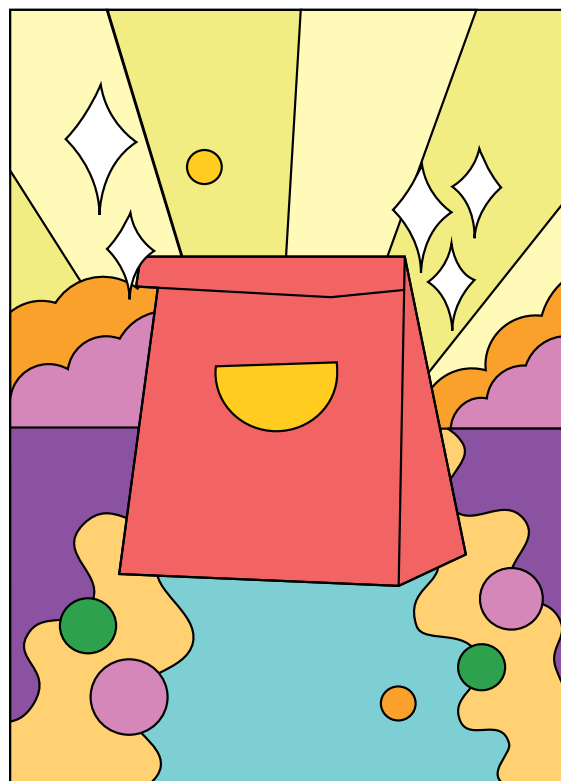

Brown paper food bag

Background notes

led by the Spirit in the wilderness

The Gospel readings for Lent in the lectionary start with one of the accounts of Jesus in the wilderness. These stories echo the time when the young nation of Israel wandered in the desert, with Jesus reliving and, in some way, redeeming that experience.¹

1 C. F. Evans, *Saint Luke* (1990) SCM, London, p. 256.

The wilderness was often viewed as a place inhabited by wild animals and demons.² Since the Holy Spirit led Jesus there, a spiritual confrontation seems inevitable – a theme that continues throughout Luke-Acts.³

forty days

The number forty links Jesus' time in the wilderness to the Israelites' journey, each day for Jesus symbolising a year for Israel (see Deuteronomy 8:2).

'One does not live by bread alone.'

Jesus quotes Deuteronomy 8:3 here, but he omits the next part: "...but by every word that comes from the mouth of the Lord", which Matthew includes.⁴ This resource will explore what, beyond literal food, sustains us in life, taking Luke's omission as a prompt.

'Worship the Lord your God, and serve only him.'

Jesus' second response to the Devil quotes Deuteronomy 6:13, connecting to the Exodus story. In the preceding verse, Moses reminds Israel not to forget that God freed them from slavery in Egypt.⁵

'Do not put the Lord your God to the test.'

In his final response, Jesus quotes Deuteronomy 6:16, referring to the time when Israel tested God at Massah and Meribah, where water flowed from a stone (Exodus 17:1-7). In this wilderness scene, Jesus reenacts Israel's temptations, but he overcomes where his ancestors failed.⁶

Questions for discussion

Here are some discussion questions that could help facilitate a deeper exploration of the themes surrounding Jesus' time in the wilderness.

- **"One does not live by bread alone"** Jesus quotes from Deuteronomy 8:3 here, though Luke's account leaves out "...but by every word that comes from the mouth of the Lord." What are some ways God sustains us beyond our physical needs?
- **The Wilderness as a metaphor** Let's explore how the wilderness embodies both struggle and preparation in our spiritual journeys. Have you ever gone through a 'wilderness' moment in your life? What valuable lessons did you learn from it?
- **Jesus as the true Israel** In each temptation, Jesus chose obedience over what Israel struggled with in the exodus. How does Jesus' obedience in the wilderness help us understand his role as a redeemer and a new representative for humanity?

2 Joseph A. Fitzmeyer, *The Gospel According to Luke* (1981) Doubleday, New York, p. 514.

3 Joel B. Green, *The Gospel of Luke* (1997) Eerdmans, Grand Rapids, p. 192.

4 Fitzmeyer, p. 515.

5 Evans, p. 259.

6 Fitzmeyer pp. 511-512.

Prayer ideas

Hold up a selection of fruit and vegetables as a prompt to prayer:

- **A bunch of carrots or other root vegetables** Point out that the growth happened underground, out of human sight. Pray for the work of God going on unseen in the lives of people in the community.
- **A head of broccoli or cauliflower** Point out the intricate detail of the florets, each one a small scale version of the whole head. Pray for the church as a global whole, for the various branches and denominations and the faith community gathered here as one small flower.
- **A fruit with obvious seeds, like an apple** Point out the way that the fruit is designed to spread the DNA of the plant far and wide. Pray for the spreading of the good news, that we might be faithful bearers of the gospel.

Make sure to tell people that this food will be eaten, as we do not want to be wasteful, especially when many people are struggling to afford food.

Pray for justice for people experiencing poverty, that they may be able to afford decent, healthy food that brings them joy, and for the work of charities who are providing affordable food for people who need help at the moment.

The good news to get across



We all need many kinds of nourishment beyond just food – things that sustain our hearts, minds and spirits. Lent offers an invitation to explore these deeper sources of nourishment and reflect on what truly feeds us.

Ways people can respond

Provide each person with a small piece of paper and write 'Shopping list' at the top. Ask them to list what they believe they need to stay well nourished at the moment, including food, friends, shelter and other essentials.

Hands-on activity

Make a junk journal binder to make notes in through Lent. There are downloadable pages to print out at methodist.org.uk/SoulFood

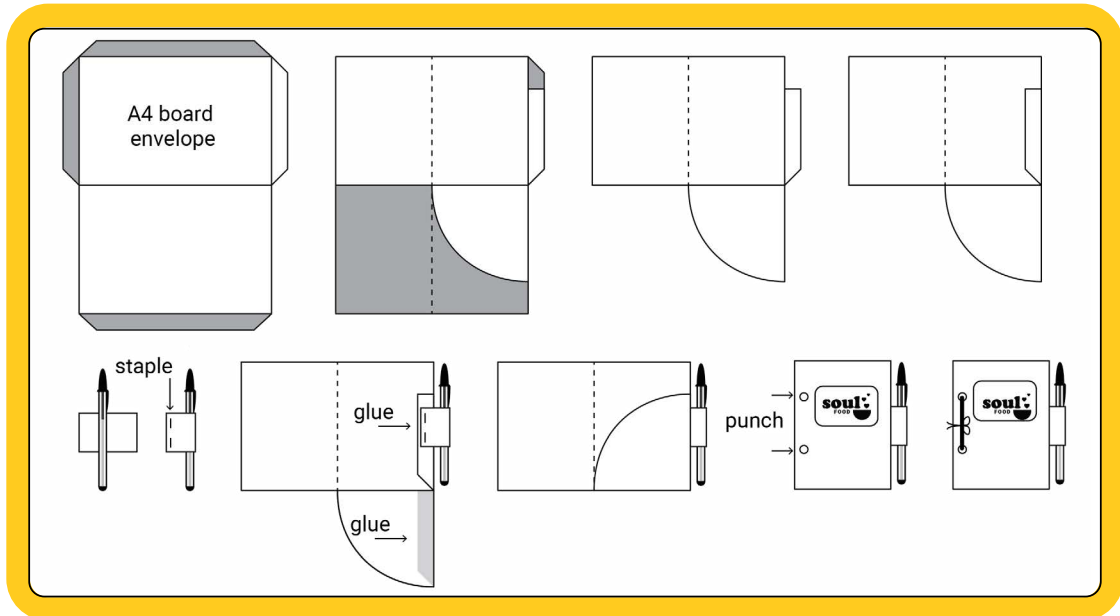

Prayer of blessing

May the God who faced the wilderness feed your soul today. **Amen.**

Sunday 16 March 2025

Lent 2: Soul Shelter

All nourished by a safe home (for everyone)

Bible readings

Psalm 27

The Lord is my light and my salvation;
whom shall I fear?

The LORD is the stronghold of my life;
of whom shall I be afraid?

When evildoers assail me
to devour my flesh—
my adversaries and foes—
they shall stumble and fall.

Though an army encamp against me,
my heart shall not fear;

**though war rise up against me,
yet I will be confident.**

**One thing I asked of the LORD;
this I seek:**

**to live in the house of the LORD
all the days of my life,**

to behold the beauty of the LORD,
and to inquire in his temple.

For he will hide me in his shelter
in the day of trouble;

he will conceal me under the cover of his tent;
he will set me high on a rock.

Now my head is lifted up
above my enemies all around me,
and I will offer in his tent

sacrifices with shouts of joy;
I will sing and make melody to the LORD.

Hear, O LORD, when I cry aloud;
be gracious to me and answer me!

“Come,” my heart says, “seek his face!”
Your face, LORD, do I seek.

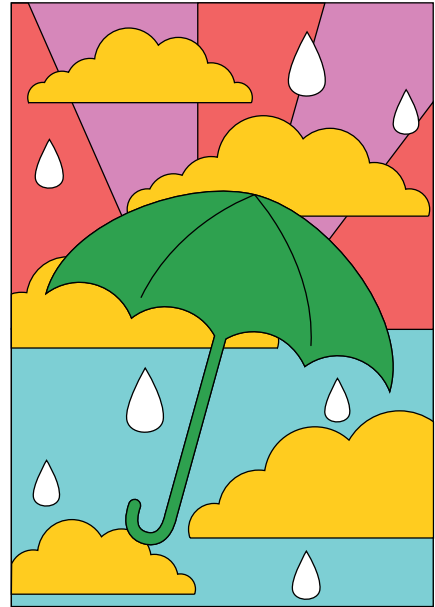

Do not hide your face from me.
Do not turn your servant away in anger,
you who have been my help.
Do not cast me off; do not forsake me,
O God of my salvation!
If my father and mother forsake me,
the Lord will take me up.
Teach me your way, O LORD,
and lead me on a level path
because of my enemies.
Do not give me up to the will of my
adversaries,
for false witnesses have risen against me,
and they are breathing out violence.
I believe that I shall see the goodness of the
LORD
in the land of the living.
Wait for the LORD;
be strong, and let your heart take courage;
wait for the LORD!

Luke 13:31-35

At that very hour some Pharisees came
and said to him, “Get away from here, for
Herod wants to kill you.” He said to them,
“Go and tell that fox for me, ‘Listen, I am
casting out demons and performing cures
today and tomorrow, and on the third day I
finish my work. Yet today, tomorrow, and the



next day I must be on my way, because it is impossible for a prophet to be killed outside of Jerusalem.' Jerusalem, Jerusalem, the city that kills the prophets and stones those who are sent to it! **How often have I desired to gather** your children together as a **hen gathers**

her brood under her wings, and you were not willing! See, your house is left to you. And I tell you, you will not see me until the time comes when you say, 'Blessed is the one who comes in the name of the Lord.' "

Songs and hymns

Be thou my vision (StF 545)

Christ the heavenly food that gives
(website only)

Community of Christ, who make the cross
your own (StF 681)

Longing for light, we wait in darkness
(StF 706)

Gather us in ("Here in this place a new light is streaming") (Marty Haugen songlyrics.com/marty-haugen/gather-us-in-lyrics/
Also *Church Hymnary 4* 623 / *Ancient and Modern* 363)

O God of Bethel, by whose hand (StF 475)

The Lord is my light, my light and salvation
(Psalm 27) (John Bell [Many and Great ionabooks.com/product/the-lord-is-my-light-downloadable-music-track/](https://ionabooks.com/product/the-lord-is-my-light-downloadable-music-track/))

Opening liturgy

Give us this day our daily bread to shelter our soul.

As bricks and mortar give our bodies shelter, shelter our being, our souls, with your spirit.

Give us this day our daily bread to shelter our soul.

As houses protect and keep safe our physical being, hold us in the shelter and safety of your Word.

Give us this day our daily bread to shelter our soul.

As an umbrella holds back the rain and the storms, so Lord be our umbrella, our tent, our shelter in life's uncertain times.

O Lord our God, on this Lenten journey, **shelter us in the struggling world's uncertainties.**
Amen.

Object

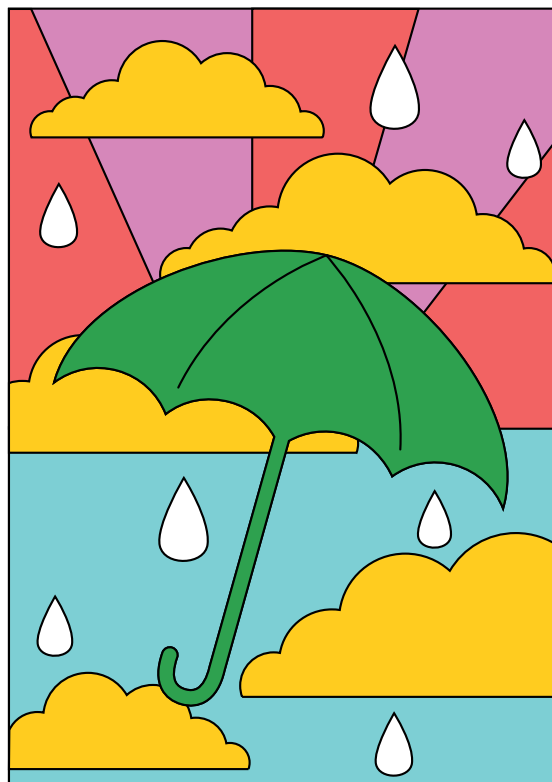

An umbrella, or some kind of tent or shelter

Background notes

Jerusalem, Jerusalem...

Jesus' brief speech is an example of a literary device called an apostrophe, in which someone absent or distant is addressed as if they were present. Repeating the name is common in apostrophes, such as "O Romeo, Romeo! wherefore art thou Romeo?"¹ Here, Jesus addresses Jerusalem, a symbol representing the entire nation of Israel.²

How often have I desired to gather

The word gather is commonly used to express the hope for God's universal restoration. For instance, Isaiah 56:7-8 says:

...for my house shall be called a house of prayer for all peoples.

Thus says the Lord God, who gathers the outcasts of Israel,

I will gather others to them besides those already gathered...

This passage highlights God's promise to bring home all people in a restored relationship.³

as a hen gathers her brood under her wings

Jesus uses a beautiful image of himself as a mother bird, expressing his deep care and desire to protect. This nurturing imagery is also found in Deuteronomy 32:11, where God is compared to an eagle caring for its young; in Psalm 17:8, which speaks of being hidden "in the shadow of [God's] wings"; and in Ruth 2:12, where Ruth is blessed for seeking refuge under God's wings. Each passage highlights God's protective love and shelter.⁴

Questions for discussion

Here are some discussion questions based on these insights into Jesus' lament over Jerusalem. These questions aim to encourage reflection on the depth of God's compassion and the barriers to experiencing it, inviting participants to connect personally with Jesus' message.

- **The hen and her brood** Jesus uses a sweet and caring image, comparing himself to a hen taking care of her chicks under her wings. What does this tell us about how he cared for the people of Jerusalem – and, by extension, for all of humanity?
- **Protective imagery in Scripture** Have you noticed how Jesus' image of gathering as a mother bird is echoed in other Bible passages like Deuteronomy 32:11, Psalm 17:8, and Ruth 2:12? These similar images tell us a lot about God's character as a protector. How does it make you feel to think of finding shelter 'under God's wings'?
- **Addressing the City** How does Jesus' direct address to Jerusalem encourage us to consider the spiritual and social health of our own cities and communities? What kind of gathering or restoration might God long for in your context?

1 Evans, pp. 563-564.

2 Green, p. 537.

3 Evans, pp. 564-565.

4 Fitzmeyer, p. 1036.

Prayer ideas

Stick pieces of paper on the walls in different areas to represent the different rooms in a home as a prompt to pray about each type of shelter. If feasible, everyone could gather in each zone to pray together and then move on to the next 'room', or alternatively the worship leader could travel between the zones on behalf of everyone. Feel free to adapt these suggestions to the local context.

- **Kitchen:** Give thanks for the food and drink that we all enjoy. Pray for people who are struggling to buy food.
- **Lounge:** Give thanks for relaxation and conversation. Pray for people who are lonely.
- **Bedroom:** Give thanks for sleep and restoration. Pray for people who are suffering from anxiety and stress.
- **Bathroom:** Give thanks for health and hygiene. Pray for people who are suffering from ill health.
- Pray for people who are homeless, that they may find safe shelter.

The good news to get across



God desires a safe home for everyone and we are called to advocate for justice and peace for all. Through our actions and commitment, we can contribute to creating a world where everyone is secure.

Ways people can respond

Give everyone a sugar cube to hold. Ask them to pray silently to God about their homes, expressing both their wishes and gratitude. Then, have them place their sugar cubes on a table with the others, using them as blocks to create a scene of shelter. People may choose to create a street or a block of flats. As they do this, take a moment to pray for the local community and for those who currently lack a safe home.

Hands-on activity

Make a paper tent as a way of reflecting on how it feels to be sheltered and dry. You could write the key Bible verses on the outside of the tent.

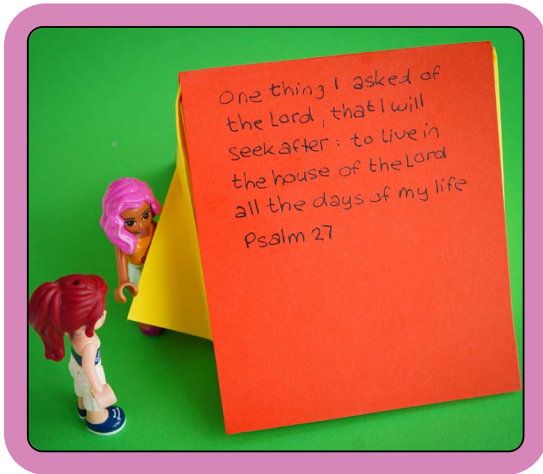
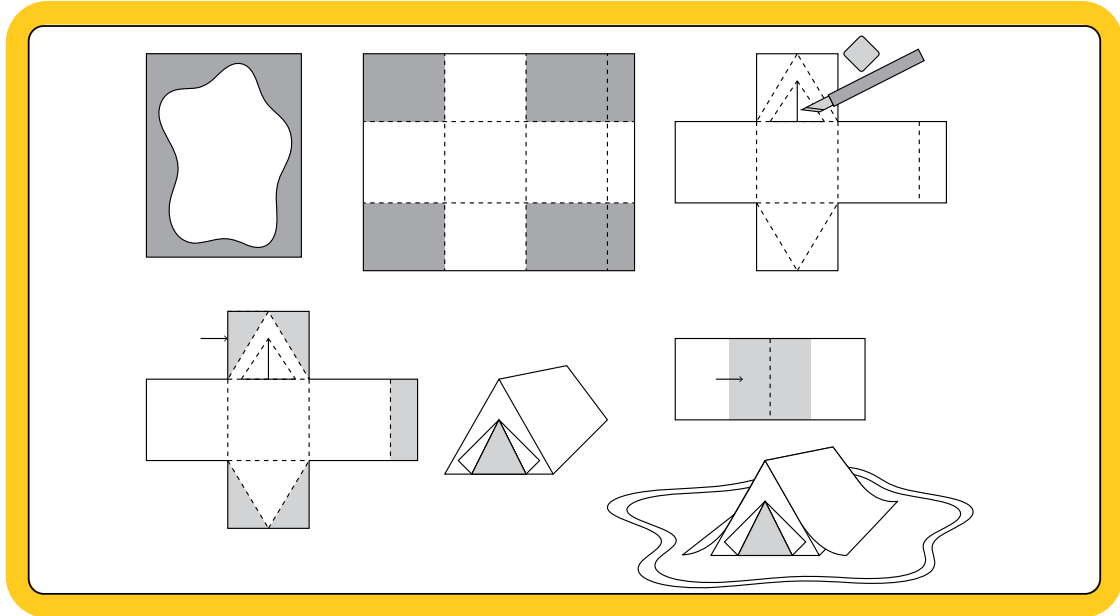

Prayer of blessing

May God, the mother hen, shelter your soul today. **Amen.**

Sunday 23 March 2025

Lent 3: Soul Rest

Nourished by patience and slowness

Bible readings

Psalm 63:1-8

O God, you are my God; I seek you;
my soul thirsts for you;
my flesh faints for you,
as in a dry and weary land where there is no
water.
So I have looked upon you in the sanctuary,
beholding your power and glory.
Because your steadfast love is better than life,
my lips will praise you.
So I will bless you as long as I live;
I will lift up my hands and call on your name.
My soul is satisfied as with a rich feast,
and my mouth praises you with joyful lips
when I think of you on my bed
and meditate on you in the watches of the
night,
for you have been my help,
and in the shadow of your wings I sing for
joy.
My soul clings to you;
your right hand upholds me.

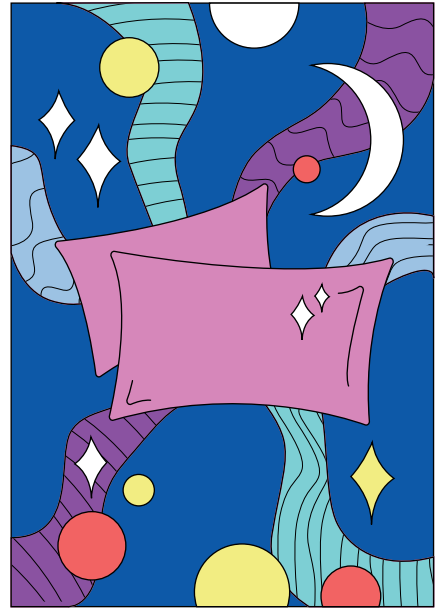

Luke 13:1-9

At that very time there were some present who told Jesus about the Galileans whose blood Pilate had mingled with their sacrifices. He asked them, “Do you think that because these Galileans suffered in this way they were worse sinners than all other Galileans? No, I tell you, but unless you repent you will all perish as they did. Or those eighteen who were killed when the tower of Siloam fell on them – do you think that they were worse offenders than all the other people living in Jerusalem? No, I tell you, but unless you repent you will all perish just as they did.”

Then he told this parable: “A man had a **fig tree** planted in his vineyard, and he came looking for fruit on it and found none. So he said to the man working the vineyard, ‘See here! For three years I have come looking for fruit on this fig tree, and still I find none. Cut it down! Why should it be wasting the soil?’ He replied, ‘Sir, **let it alone for one more year, until I dig around it and put manure on it. If it bears fruit next year**, well and good, but if not, you can cut it down.’ ”



Songs and hymns

God, beyond our dreams, you have shared
in us a memory (StF 496)

My soul finds rest in God alone (StF 633)

O love that wilt not let me go (StF 636)

The King of love my shepherd is (StF 479)

The Lord's my shepherd, I'll not want
(StF 481) Stuart Townend ver.

We follow the Lord along the gradual road
to heaven (StF 730)

We pray until the hour (StF 741)

We trust the mighty love of God (StF 742)

When we are living, we are in the Lord
(StF 485)

Opening liturgy

*Give us this day our daily bread to give
our soul rest.*

In a fast-paced world that seems never to rest or sleep,
in an internet world of immediate response...

*Give us this day our daily bread to give
our soul rest.*

Let us find that calm centre, that stillness
and rest,
that moment of comfort, refreshment
and peace...

*Give us this day our daily bread to give
our soul rest.*

To find meaning and purpose, to see the
way forward,
with you as our pillow in the moment of tiredness.

O Lord our God, on this Lenten journey,
**let us rest in the knowledge of your peace
and your calm. Amen.**

Object

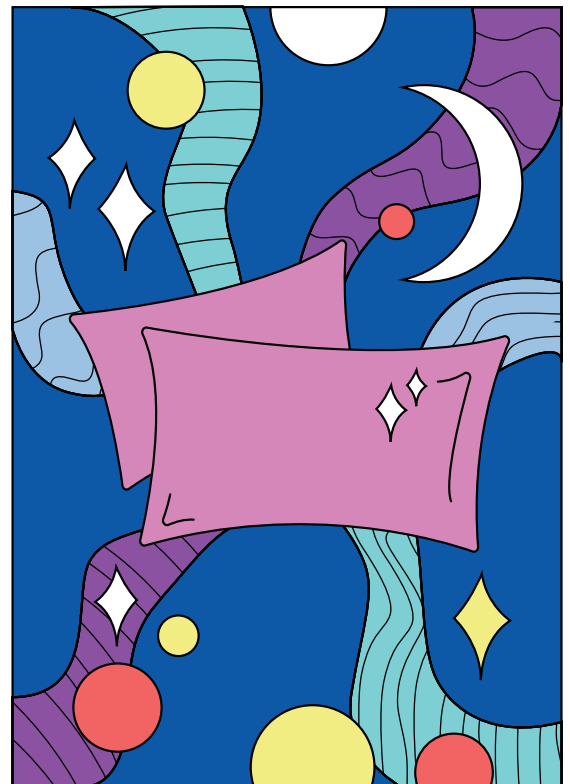

A pillow

Background notes

...a fig tree...

In the Old Testament, fig trees planted in vineyards often symbolise Judah or Israel. For example, Hosea 9:10 describes Israel as "like grapes in the wilderness," with fig trees as a metaphor for God's people. Micah 7:1 uses the imagery of fruit trees to reflect the prophet's sorrow over Israel's spiritual state, and Jeremiah 8:13 speaks of withering figs as a symbol of Israel's judgment and lost blessings.¹

¹ Fitzmeyer, p. 1008.

...let it alone for one more year, until I dig around it and put manure on it.

Stories about fruitless trees existed well before Jesus' time, and he appears to draw on a familiar tale for this teaching. However, in Jesus' version, a notable difference is that the gardener responds with leniency and care, choosing to tend to the tree rather than cutting it down immediately. This compassionate approach highlights a theme of patience and the opportunity for growth and renewal if things are well nourished and given time to rest.²

If it bears fruit next year...

In Jesus' version of the story, there is a hopeful message: this seemingly hopeless tree still has the potential to thrive if given more time. Contrary to the owner's belief that the tree is a "waste of soil," Jesus' story suggests that with patience and care, even what seems useless can bear fruit. This reflects a theme of second chances and the belief in redemption and restoration for all.³

Questions for discussion

Here are discussion questions to explore the meaning of the fig tree parable and its symbolism. These questions are designed to prompt reflections on patience, growth and the potential for transformation, encouraging us to see both ourselves and others through the lens of grace and renewal.

- **God, the lenient gardener** The gardener's response is to nurture the tree rather than cut it down. What does this say about God's character, and how does it contrast with the expectations of immediate judgment?
- **Redemption for the fruitless tree** Jesus' parable gives hope that even a seemingly "waste of soil" tree can bear fruit. How does this idea of second chances resonate with you? Where might we see this theme of redemption and potential in our own lives? How do you think the passage in Matthew (21:18-22) where Jesus curses a fruitless fig tree relates to this passage, if at all?
- **Our role as gardeners** If we see ourselves as gardeners in others' lives, what actions can we take to nurture and encourage their spiritual growth? How can we embody this same patience and hope?

Prayer ideas

Spend a few minutes in silent prayer. Allow your minds to wander and to daydream.

The good news to get across

Rest and reflection are essential, not only for the sake of productivity but because they hold intrinsic value. Taking time to pause allows us to reconnect with ourselves and our purpose, nurturing our wellbeing and deepening our understanding of life.

² Green, p. 515.

³ Green, p. 515.

Hands-on activities

Sew mini pillows from felt.

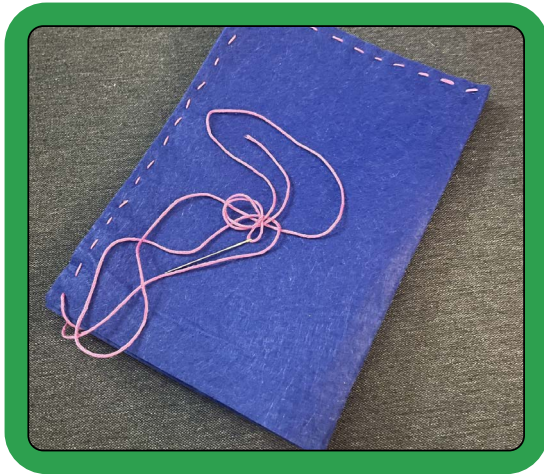
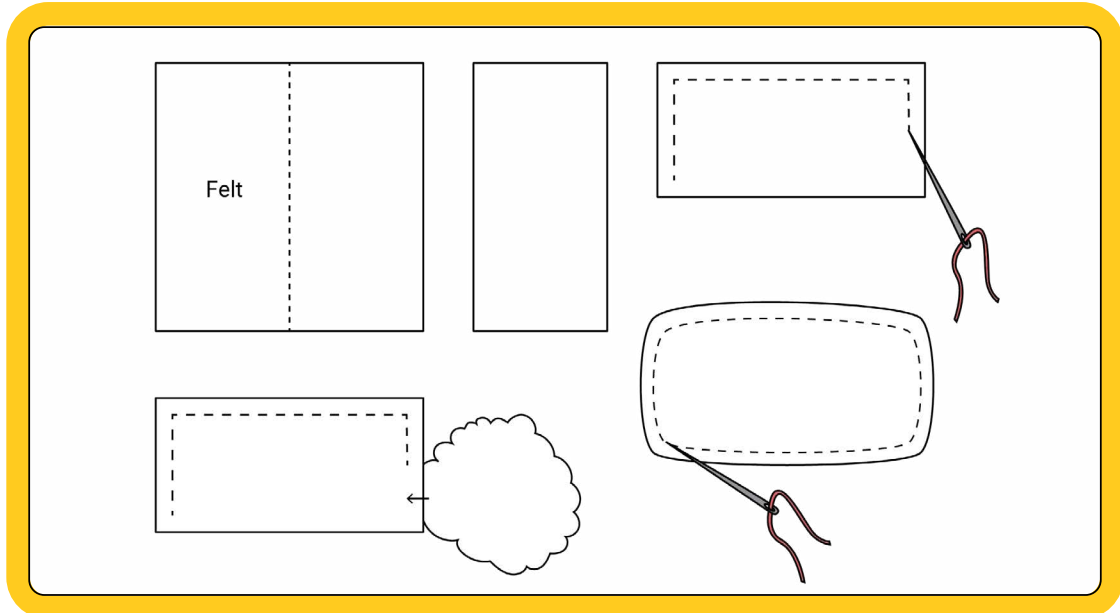

Ways people can respond

Take a few minutes to be silent and invite people to prayerfully daydream. Let their minds wander as they relax.

Prayer of blessing

May God, the patient gardener,
provide rest and nurture for your soul today. **Amen.**

Sunday 30 March 2025

Lent 4: Soul Repair

Nourished by unconditional love and forgiveness (Mothering Sunday)

Bible readings

Psalm 32

Happy are those whose transgression is forgiven,
whose sin is covered.

Happy are those to whom the LORD imputes no iniquity
and in whose spirit there is no deceit.

While I kept silent, my body wasted away
through my groaning all day long.

For day and night your hand was heavy upon me;

my strength was dried up as by the heat of summer. *Selah*

Then I acknowledged my sin to you,
and I did not hide my iniquity;

I said, "I will confess my transgressions to the LORD,"

and you forgave the guilt of my sin. *Selah*

Therefore let all who are faithful
offer prayer to you;

at a time of distress, the rush of mighty waters
shall not reach them.

You are a hiding place for me;
you preserve me from trouble;
you surround me with glad cries of deliverance. *Selah*

I will instruct you and teach you the way you
should go;

I will counsel you with my eye upon you.

Do not be like a horse or a mule, without understanding,
whose temper must be curbed with bit and
bridle,

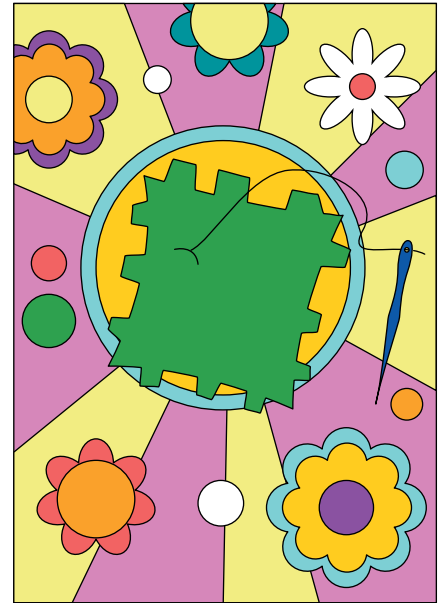

else it will not stay near you.

Many are the torments of the wicked,
but steadfast love surrounds those who trust
in the LORD.

Be glad in the LORD and rejoice, O righteous,
and shout for joy, all you upright in heart.

Luke 15:1-3, 11b-32

Now all the tax collectors and sinners
were coming near to listen to him. And the
Pharisees and the scribes were grumbling and
saying, "This fellow welcomes sinners and
eats with them."

So he told them this parable:

Then Jesus said, "There was a man who
had two sons. The younger of them said to
his father, 'Father, give me the share of the
wealth that will belong to me.' So he divided
his assets between them. A few days later the
younger son gathered all he had and traveled
to a distant region, and there he squandered
his wealth in dissolute living. When he had
spent everything, a severe famine took place
throughout that region, and he began to be in
need. So he went and hired himself out to one
of the citizens of that region, who sent him
to his fields to feed the pigs. He would gladly
have filled his stomach with the pods

that the pigs were eating, and no one gave him anything. But when he came to his senses he said, 'How many of my father's hired hands have bread enough and to spare, but here I am dying of hunger! I will get up and go to my father, and I will say to him, "Father, I have sinned against heaven and before you; I am no longer worthy to be called your son; treat me like one of your hired hands."' So he set off and went to his father. **But while he was still far off**, his father saw him and was **filled with compassion**; he ran and **put his arms around him and kissed him**. Then the son said to him, 'Father, I have sinned against heaven and before you; I am no longer worthy to be called your son.' But the father said to his slaves, 'Quickly, bring out a robe—the best one—and put it on him; put a ring on his finger and sandals on his feet. And get the fatted calf and kill it, and let us eat and celebrate, for this son of mine was dead and is alive again; he was lost and is found!' And they began to celebrate.

"Now his elder son was in the field, and as he came and approached the house, he heard music and dancing. He called one of the slaves and asked what was going on. He replied, 'Your brother has come, and your father has killed the fatted calf because he has got him back safe and sound.' Then he became angry and refused to go in. His father came out and began to plead with him. But he answered his father, 'Listen! For all these years I have been working like a slave for you, and I have never disobeyed your command, yet you have never given me even a young goat so that I might celebrate with my friends. But when this son of yours came back, who has devoured your assets with prostitutes, you killed the fatted calf for him!' Then the father said to him, 'Son, you are always with me, and all that is mine is yours. But we had to celebrate and rejoice, because this brother of yours was dead and has come to life; he was lost and has been found.' "

Songs and hymns

Bread is blessed and broken (*StF* 576)

Have faith in God, my heart (*StF* 466)

How blessed are we (Psalm 32)
(Brian Wren, *In God Rejoice* 2012,
stainer.co.uk/shop/b934/)

Praise, my soul, the King of heaven (*StF* 83)

Today we bring our thankful hearts (Ally Barrett jubilate.co.uk/songs/today-we-bring-our-thankful-hearts Also: *God Welcomes All* #112 – Tune: O Waly Waly, *StF* 569)

Where shall my wondering soul begin?
(*StF* 454)

Opening liturgy

Give us this day our daily bread to repair our soul.

We have broken bits and worn out bits and missing bits;
bits that make us much less whole...

Give us this day our daily bread to repair our soul.

Life challenges, damages, hurts and scars us,
body, mind and spirit all...

Give us this day our daily bread to repair our soul.

Be our balm, the loving thread that gently tends our wounds,
the thread and patch that makes us whole.

O Lord our God, on this Lenten journey,
repair our broken fragile bits. Amen.

Object

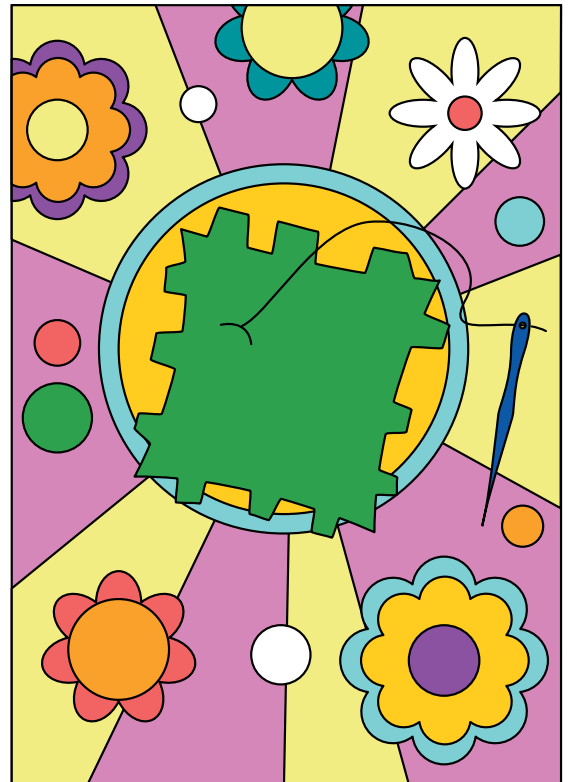

**A piece of fabric with
a sewn-up hole**

Background notes

But while he was still far off...

Jesus teaches a core principle about God's relationship with flawed people: God loves them even before they repent or apologise.¹ The younger son's apology is almost lost amid the father's eager welcome and act of restoration.² This beautifully illustrates prevenient grace – the belief that God seeks us long before we seek God. The God who is present everywhere is also everywhere active, continually calling all to come home.

...filled with compassion...

The Greek word translated as compassion literally means "to feel it in the bowels". Similar English expressions, like "gutted," or "butterflies in my stomach", or "gut-wrenching", convey this deep, physical feeling.³ It describes a visceral, embodied love – an intense contrast to the elder brother's anger later in the story. This word captures the father's raw, heartfelt love, as opposed to the elder brother's more equally visceral reaction of anger.⁴

...put his arms around him and kissed him.

The literal translation is "he fell upon his neck and kissed him." This imagery may reference Genesis 33:4, which recounts the reconciliation of Jacob and Esau. In that story, Esau embraces Jacob after many years apart, signifying forgiveness and the restoration of their relationship. Similarly, in Jesus' parable, the father's embrace of his returning son symbolises deep love and reconciliation.

1 Fitzmeyer, p. 1086.

2 Green, p. 582.

3 Fitzmeyer, p. 1089.

4 Green, pp. 582-583.

Questions for discussion

Here are discussion questions based on these themes from the parable of the prodigal son. These questions invite reflection on the depths of God's love and the transformative power of grace, encouraging participants to explore how they can embody this in their own lives.

- **Unconditional love** Jesus illustrates that the father's love comes before any apology from the son. How does this demonstrate God's **prevenient grace** – the idea that God's love and presence are with us even before we turn back to God?
- **The depth of compassion** The Greek term for compassion, which literally means "to feel it in the bowels", suggests a profound, physical response. How does this image affect your understanding of God's love? When have you experienced or witnessed such intense compassion?
- **Homecoming and reconciliation** The father's welcome symbolises the joy of a homecoming. What does "coming home" mean to you spiritually? How does it feel to imagine being welcomed in this way?

Prayer ideas

Give everyone a paper or wooden heart to hold.

Ask them to think of themselves as the heart, held in God's hands, loved and cherished.

Then ask them to think of the heart as representing the people they love the most. Thank God for these relationships.

The good news to get across



Despite all the ways we may try to distance ourselves from God, God continually seeks us out. God's love, compassion and presence can heal our shame, failure and isolation. What aspects of that message have stayed with you over the past year. What insights or experiences have resonated deeply, reminding you of God's unwavering presence and affection?

Ways people can respond

Give everyone some time to re-imagine the scene of reconciliation, with themselves as the prodigal son. Encourage them to experience the profound sense of unconditional love from God.

Since it's Mothering Sunday, you might consider giving everyone a flower as a token of appreciation. However, be mindful that this day can be emotionally charged for people, for various reasons. Regardless of gender, encourage everyone to reflect on how they can offer 'motherly love' to others.

Hands-on activity

Make a pop-up card of a pair of hands holding a heart. This symbolises the nature of God's unchanging love for each of us. A template of the hand and heart images can be downloaded from methodist.org.uk/SoulFood

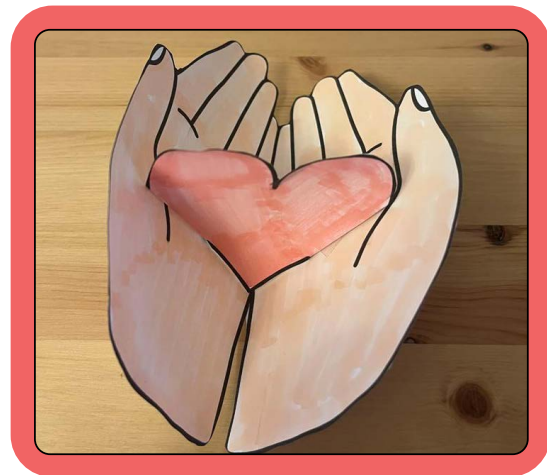
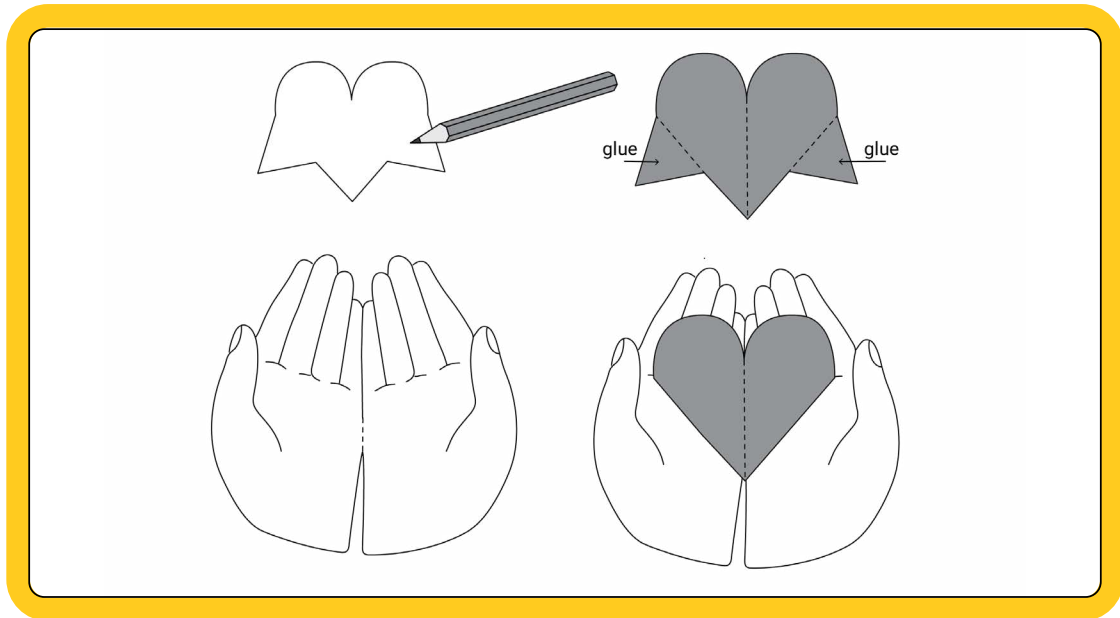

Prayer of blessing

May God, the loving parent, embrace your soul today.

Amen.

Sunday 6 April 2025

Lent 5: Soul Mates

Nourished by companionship

Bible readings

Psalm 126

When the LORD restored the fortunes of Zion,
we were like those who dream.

Then our mouth was filled with laughter
and our tongue with shouts of joy;

then it was said among the nations,
“The LORD has done great things for them.”

The LORD has done great things for us,
and we rejoiced.

Restore our fortunes, O LORD,
like the watercourses in the Negeb.

May those who sow in tears
reap with shouts of joy.

Those who go out weeping,
bearing the seed for sowing,
shall come home with shouts of joy,
carrying their sheaves.

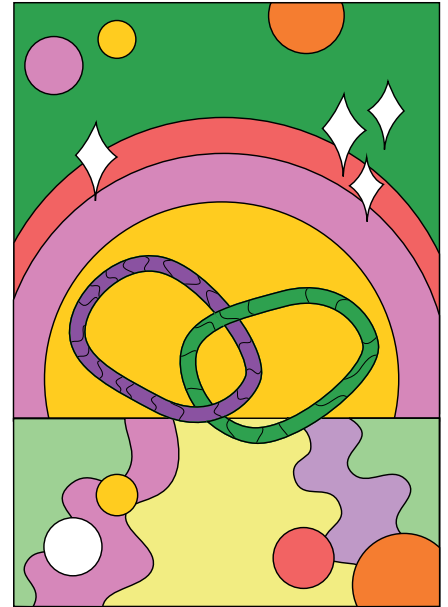

John 12:1-8

Six days before the Passover **Jesus came to Bethany**, the home of Lazarus, whom he had raised from the dead. **There they gave a dinner for him. Martha served**, and Lazarus was one of those reclining with him. **Mary took a pound of costly perfume made of pure nard, anointed Jesus's feet, and wiped them with her hair.**

The house was filled with the fragrance of the perfume. But Judas Iscariot, one of his disciples (the one who was about to betray him), said, **“Why was this perfume not sold for three hundred denarii and the money given to the poor?”** (He said this not because he cared about the poor but because he was a thief; he kept the common purse and used to steal what was put into it.) Jesus said, **“Leave her alone.** She bought it so that she might keep it **for the day of my burial.** You always have the poor with you, but you do not always have me.”

Songs and hymns

Fear not, for I am with you (website only)
For the beauty of the earth (StF 102)

O Lord, my God, when I in awesome wonder
("How great thou art") (StF 82)

O thou who this mysterious bread (StF 597)

Said Judas to Mary, "Now What Will
You Do" (Sydney Carter eg [godsongs.net/2019/03/said-judas-to-mary-ointment-so-rich-and-so-rare-cross-of-the-world-carter.html](https://www.godsongs.net/2019/03/said-judas-to-mary-ointment-so-rich-and-so-rare-cross-of-the-world-carter.html))

Thanks for friends who keep on loving
(StF 619)

Thou God of truth and love (StF 620)

We walk the way of love (Stephen Best
[worshipwords.co.uk/we-walk-the-way-of-love-stephen-best-uk/](https://www.worshipwords.co.uk/we-walk-the-way-of-love-stephen-best-uk/))

We will walk with God, my brothers
(StF 484)

What a friend we have in Jesus (StF 531)

Opening liturgy

*Give us this day our daily bread to cement
our friendship...*

That we may feel loved, wanted, needed,
cared for,
that we may offer love and care where it
is needed.

*Give us this day our daily bread to cement
our friendship...*

That we may live companionably with you
our soul friend,
that we may live companionably with our
friends and neighbours.

*Give us this day our daily bread to cement
our friendship...*

That together with you we can be love and
hope for others,
that together we are there for each other.

O Lord our God, on this Lenten journey,
**be our friend, let us be friends and let us be
be-friended, we pray. Amen.**

Object

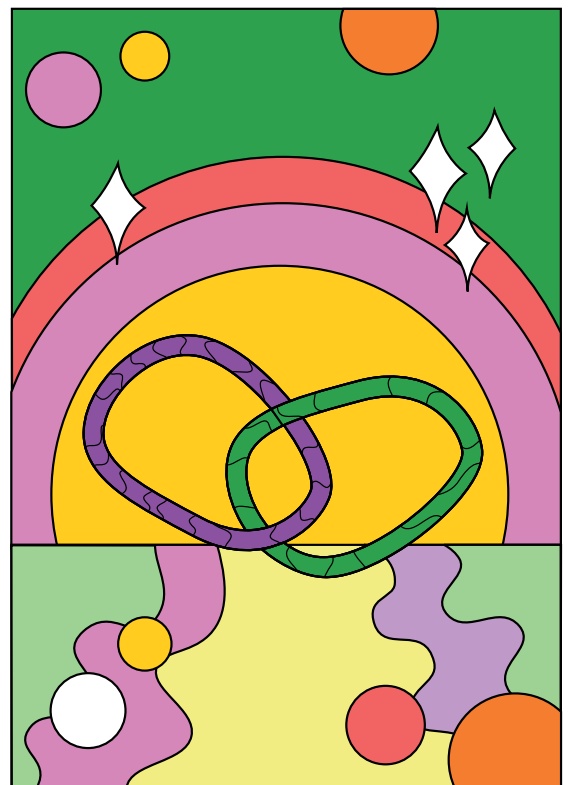

Friendship bracelets

Background notes

Jesus came to Bethany..

The four Gospels seem to record two distinct events that are sometimes conflated. This dinner at Bethany appears here in John and in Mark 14:3-9 and Matthew 26:6-13, where it takes place in the house of Simon the Leper, who is not mentioned in John. In Mark and Matthew, an unnamed woman anoints Jesus' head with nard. In contrast, Luke 7:36-38 describes an unnamed "sinner" who anoints Jesus' feet and wipes them with her hair, but this takes place in the house of Simon, a Pharisee, in the Galilee region. John's account seems to blend elements from both traditions, depicting the anointing of Jesus' feet and omitting Simon the Leper. Later in church history, these stories were further merged. Luke's reference to the woman as a "sinner" was associated with Mary in John's account and then mistakenly linked with another figure, Mary Magdalene, who had seven demons cast out in Luke 8:2. This fusion of stories may have contributed to the questionable tradition that Mary Magdalene was particularly sinful or even a former prostitute – an idea not supported by the biblical text.¹

There they gave a dinner for him. Martha served...

The scene is one of close companionship and intimacy, Jesus among his friends.² The same Greek word for "served" appears shortly afterward in John 12:26: "Whoever serves me, the Father will honour." Here, service is viewed positively, in contrast to Luke 10:38-42, where Martha's service is critiqued in light of Mary's contemplative devotion. In John's account, both service and contemplation are commended, presenting a complementary balance between active service and spiritual reflection.³

Mary took a pound of costly perfume made of pure nard, anointed Jesus's feet, and wiped them with her hair.

Mary took a pound of expensive perfume made from pure nard, anointed Jesus's feet, and wiped them with her hair – a gesture that would have seemed shockingly intimate, expressing her profound devotion to Jesus. This scene evokes passages from the Song of Songs (1:2-3, 12):

For your love is better than wine; your anointing oils are fragrant; your name is perfume poured out; therefore the maidens love you ... While the king was on his couch, my nard gave forth its fragrance.

The fragrance filling the room may also symbolise the Spirit: unbounded and all-encompassing.

Why was this perfume not sold for three hundred denarii and the money given to the poor?

Oscar Wilde is credited with the quote, "The cynic knows the price of everything and the value of nothing."⁴ Mary's action was abundantly generous and extravagant, but ultimately worth it – connection to God, and each other, is priceless.

1 Raymond E. Brown, *The Gospel According to John* (1966) Doubleday, New York, pp. 449-452.

2 David Ford, *The Gospel of John*, (2021) Baker Academic, Grand Rapids, pp. 231-232.

3 Ford, p. 234.

4 Oscar Wilde, *Lady Windermere's Fan*.

Leave her alone.

This story has often been used to affirm the various roles of women within and beyond the Church, offering a strong defence against misogyny. Mary's act of devotion and leadership in this moment highlights the significance and agency of women in the ministry of Jesus, setting a model for their valued place in the Christian community.⁵

...for the day of my burial.

The anointing in John is connected to Jesus' burial, which may explain why Mary anoints Jesus' feet. Anointing the feet was unusual for living people and was typically part of preparing a body for burial. This act foreshadows Jesus' impending death, adding a layer of solemnity and significance to Mary's gesture.⁶

Questions for discussion

Here are some discussion questions that delve into the themes and context of Jesus' anointing at Bethany.

- **Mary's act of devotion** Mary's action in anointing Jesus' feet with costly perfume is both intimate and extravagant. What does this reveal about her relationship with Jesus? How does this act of love challenge us in our own expressions of faith?
- **The fragrance as a symbol** The fragrance of the perfume fills the entire house. How might this symbolise the presence of the Holy Spirit or the effect of acts of love on a community? How can our own "fragrance" of faithfulness impact others?
- **"Leave her alone"** Jesus' defence of Mary's act has often been seen as an affirmation of women's roles in ministry. How does Mary's example challenge traditional views on the role of women in the early church, and how might it inspire us today?

Prayer ideas

Give each person two pieces of embroidery thread. Tie them together with knots to represent their most important friendships, giving thanks for each one.

Pray for people who are isolated and lonely, who need more companionship in their lives.

The good news to get across

We all need companionship, which requires a generous investment of our time and resources. The rewards of building meaningful relationships, however, are priceless, enriching our lives and fostering a sense of belonging and connection that enhances our wellbeing.

5 Ford, p. 245.

6 Brown, p. 454.

Hands-on activity

Make friendship bracelets.

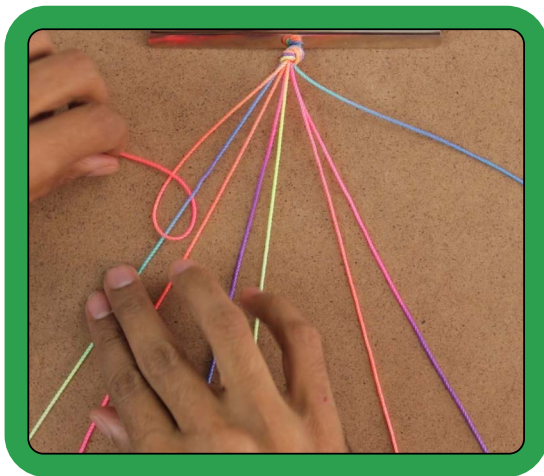
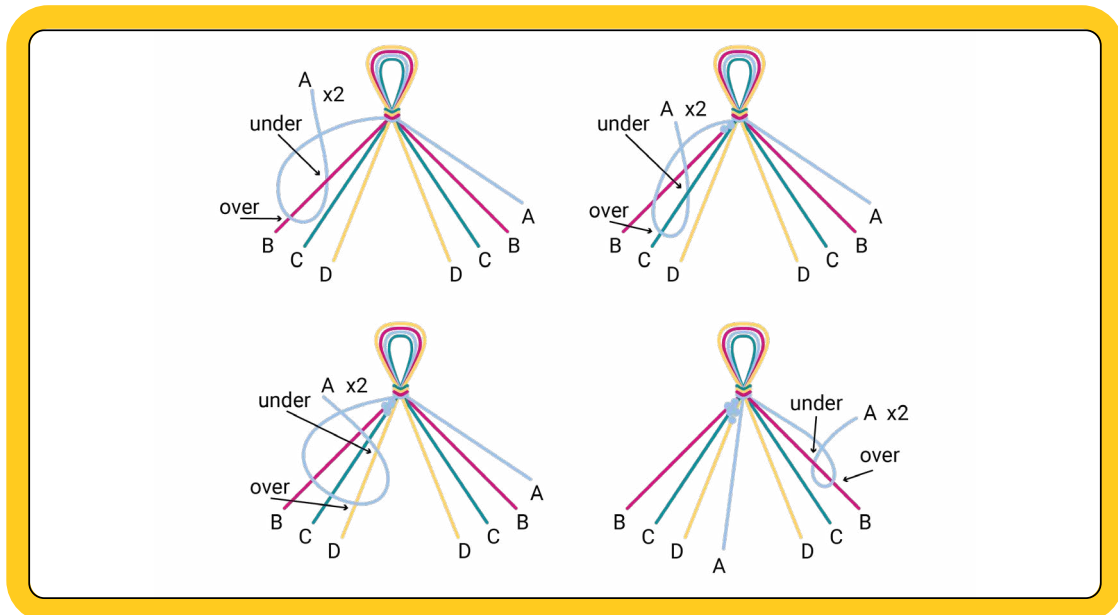

Ways people can respond

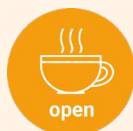

Invite people to share a story with the person sitting next to them about a time when they most benefitted from someone else's companionship.

Prayer of blessing

May God, your friend,
be like a pleasant fragrance for your soul
today.

Amen.

Sunday 13 April 2025

Palm Sunday: Soul Songs

Nourished by musical expression

Bible readings

Psalm 118:1-2, 19-29

O give thanks to the LORD, for he is good;
his steadfast love endures forever!

Let Israel say,

“His steadfast love endures forever.”

Open to me the gates of righteousness,
that I may enter through them
and give thanks to the LORD.

This is the gate of the LORD;
the righteous shall enter through it.

I thank you that you have answered me
and have become my salvation.

The stone that the builders rejected
has become the chief cornerstone.

This is the LORD’s doing;
it is marvellous in our eyes.

This is the day that the Lord has made;
let us rejoice and be glad in it.

Save us, we beseech you, O LORD!

O LORD, we beseech you, give us success!
Blessed is the one who comes in the name of
the LORD.

We bless you from the house of the LORD.

The LORD is God,
and he has given us light.

Bind the festal procession with branches,
up to the horns of the altar.

You are my God, and I will give thanks to you;
you are my God; I will extol you.

O give thanks to the LORD, for he is good,
for his steadfast love endures forever.

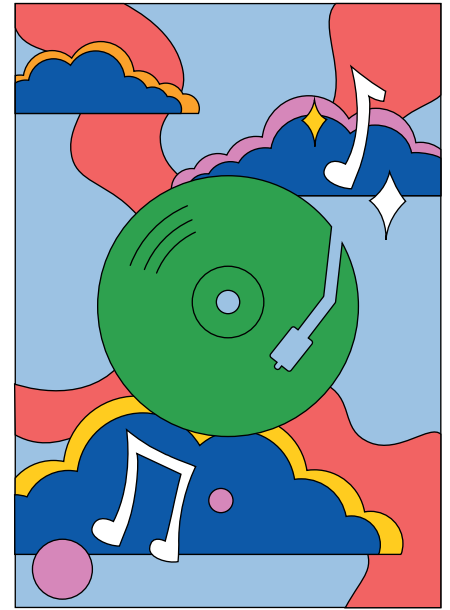

Luke 19:28-40

After he had said this, he went on ahead, going up to Jerusalem.

When he had come near Bethphage and Bethany, at the place called the Mount of Olives, he sent two of the disciples, saying, “Go into the village ahead of you, and as you enter it you will find tied there a colt that has never been ridden. Untie it and bring it here. If anyone asks you, ‘Why are you untying it?’ just say this, ‘The Lord needs it.’” So those who were sent departed and found it as he had told them. As they were untying the colt, its owners asked them, “Why are you untying the colt?” They said, “The Lord needs it.” Then they brought it to Jesus, and after throwing their cloaks on the colt, they set Jesus on it. As he rode along, people kept spreading their cloaks on the road. Now as he was approaching the path down from the Mount of Olives, the **whole multitude of the disciples began to praise God joyfully with a loud voice for all the deeds of power that they had seen**, saying,

**“Blessed is the king
who comes in the name of the Lord!
Peace in heaven,
and glory in the highest heaven!”**

Some of the Pharisees in the crowd said to him, "Teacher, order your disciples to stop." He answered, "**I tell you, if these were silent, the stones would shout out.**"

Opening liturgy

Give us this day our daily bread that lets our hearts sing...

That we can express our loves, our likes, our hates, our fears,
the depths of our joys, our sorrows, our hopes
our dreams.

Give us this day our daily bread that lets our hearts sing...

That we can live and be ourselves knowing
you hear our songs,
that we can sing out our hearts desire.

Give us this day our daily bread that lets our hearts sing...

As you know the songs of our souls, the
depths of our being,
may those others who hear them through us
see you.

O Lord our God, on this Lenten journey,
**let us sing and shout and proclaim your way,
your Word. Amen.**

Object

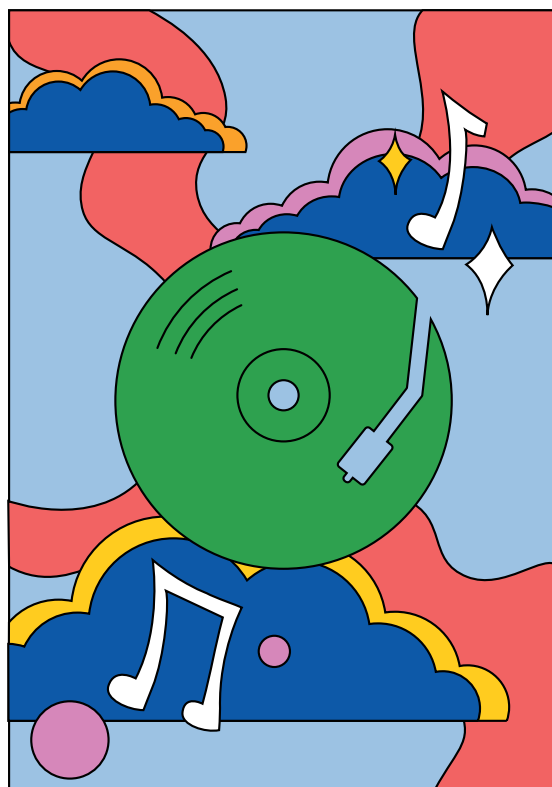

A vinyl record

Background notes

The whole multitude of the disciples began to praise God joyfully with a loud voice for all the deeds of power that they had seen...

The entire gathering of disciples began joyfully praising God with loud voices, celebrating the powerful deeds they had witnessed. Unlike in Mark's account – where the praise comes from the general unaffiliated crowd – here it is specifically the disciples who honour Jesus. Their praise has a solid basis, a response to all they had seen Jesus accomplish up to this point. This scene serves as a climactic celebration of Jesus' ministry.¹

¹ Evans, p. 680.

*“Blessed is the king who comes in the name of the Lord!
Peace in heaven, and glory in the highest heaven!”*

In Luke’s account, unlike in Mark 11:10, there is no mention of “Hosanna” or references to David. Instead, the disciples echo the angels’ song from the Christmas narrative (Luke 2:14), suggesting a fulfilment of the promises of the incarnation. Yet, there is a realistic note here: peace on earth has not yet arrived, and the word “earth” is replaced with “heaven” in this song. Referring back to the Advent/Christmas series ‘Hush the Noise’ could be helpful to remind people of the angels’ song and its message.¹

“I tell you, if these were silent, the stones would shout out.”

This may allude to Habakkuk 2:11, where stones cry out from a wall in protest against violence and injustice. Here, the idea that even inanimate stones are ready to sing suggests the cosmic significance of what is happening, as if the very fabric of nature itself is compelled to offer praise.²

Questions for discussion

Here are some discussion questions based on the themes of praise, prophecy and cosmic significance in this passage.

- **Joyful praise for deeds of power** The disciples’ praise is based on all they had seen Jesus accomplish. What powerful deeds have inspired your own faith journey? How can we incorporate joyful gratitude for God’s works in our own lives?
- **Echoes of the angels’ song** The disciples’ words here reflect the angels’ song from Luke’s Christmas narrative. How does this connection enhance our understanding of Jesus’ mission? How do you see themes of peace and glory unfolding from the beginning of Jesus’ life to this moment?
- **Silent stones and cosmic praise** Jesus says that if the disciples were silent, the stones would shout out. What does this image of nature itself offering praise suggest about the significance of Jesus’ entry into Jerusalem? How might creation “praise” or reveal God’s glory today?

Ways people can respond

Sing together *StF 82*, “O Lord, my God, when I in awesome wonder”. As people sing the line, “Then sings my soul...” encourage them to reflect on the blessings and acts of kindness that God has bestowed upon them.



The good news to get across

The death and Resurrection of Jesus brought transformation to the entire universe. Both sentient beings and inanimate creation are drawn into this renewal, as all things are encompassed in the restoration God brings.

¹ Eduard Schweizer, *The Good News According to Luke* (1984) John Knox, Atlanta p. 299.

² Fitzmeyer, p. 1252.

Prayer ideas

Give everyone a stone and a felt-tip pen. Read out again, **“I tell you, if these were silent, the stones would shout out.”** Invite people to write on the stone the things that they are thankful to God for.

Hands-on activities

Make model microphones – people can hold them and shout their praises and thanks to God.

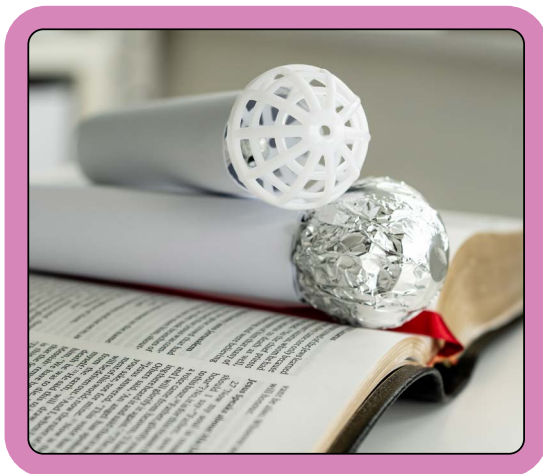
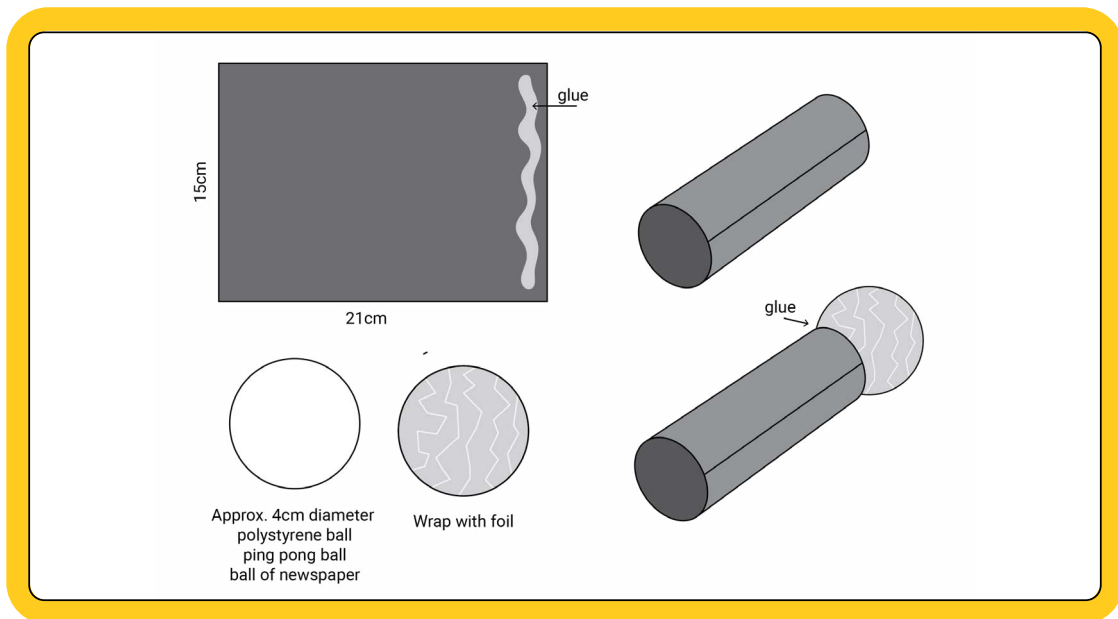

Prayer of blessing

May God, the bringer of peace, and worker of mighty deeds,
bring out songs of praise from your soul today.

Amen.

Friday 18 April 2025

Good Friday: Soul Support

Nourished by each other when
times are tough

Bible readings

Psalm 22

My God, my God, why have you forsaken me?
Why are you so far from helping me, from the
words of my groaning?

O my God, I cry by day, but you do not answer;
and by night but find no rest.

Yet you are holy,
enthroned on the praises of Israel.
In you our ancestors trusted;
they trusted, and you delivered them.
To you they cried and were saved;
in you they trusted and were not put to
shame.

But I am a worm and not human,
scorned by others and despised by the
people.

All who see me mock me;
they sneer at me; they shake their heads;
“Commit your cause to the LORD; let him
deliver—
let him rescue the one in whom he delights!”

Yet it was you who took me from the womb;
you kept me safe on my mother’s breast.
On you I was cast from my birth,
and since my mother bore me you have been
my God.

Do not be far from me,
for trouble is near,
and there is no one to help.

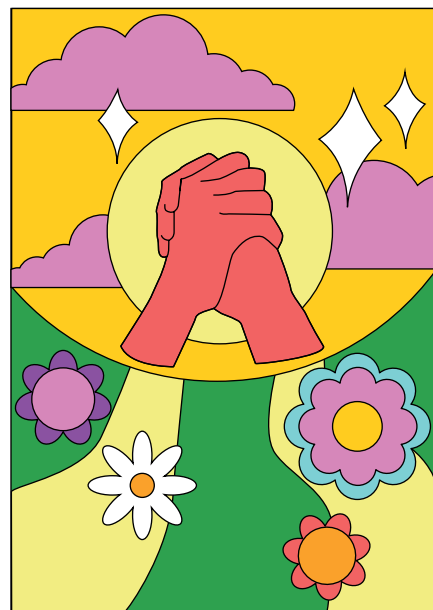

Many bulls encircle me;
strong bulls of Bashan surround me;
they open wide their mouths at me,
like a ravening and roaring lion.

I am poured out like water,
and all my bones are out of joint;
my heart is like wax;
it is melted within my breast;
my mouth is dried up like a potsherd,
and my tongue sticks to my jaws;
you lay me in the dust of death.

For dogs are all around me;
a company of evildoers encircles me;
they bound my hands and feet.
I can count all my bones.
They stare and gloat over me;
they divide my clothes among themselves,
and for my clothing they cast lots.

But you, O LORD, do not be far away!
O my help, come quickly to my aid!
Deliver my soul from the sword,
my life from the power of the dog!
Save me from the mouth of the lion!
From the horns of the wild oxen you have
rescued me.

I will tell of your name to my brothers and sisters;
in the midst of the congregation I will praise you:

You who fear the LORD, praise him!
All you offspring of Jacob, glorify him;
stand in awe of him, all you offspring of Israel!

For he did not despise or abhor
the affliction of the afflicted;
he did not hide his face from me
but heard when I cried to him.

From you comes my praise in the great congregation;
my vows I will pay before those who fear him.
The poor shall eat and be satisfied;
those who seek him shall praise the LORD.
May your hearts live forever!

All the ends of the earth shall remember
and turn to the LORD,
and all the families of the nations
shall worship before him.
For dominion belongs to the LORD,
and he rules over the nations.

To him, indeed, shall all who sleep in the earth bow down;
before him shall bow all who go down to the dust,
and I shall live for him.
Posterity will serve him;
future generations will be told about the LORD
and proclaim his deliverance to a people yet unborn,
saying that he has done it.

John 19:13-19:42

When Pilate heard these words, he brought Jesus outside and sat on the judge's bench at a place called The Stone Pavement, or in Hebrew Gabbatha. Now it was the day of Preparation for the Passover, and it was about noon. He said to the Jews, "Here is your King!" They cried out, "Away with him! Away with him! Crucify him!" Pilate asked them, "Shall I crucify your King?" The chief priests answered, "We have no king but Caesar." Then he handed him over to them to be crucified.

So they took Jesus, and carrying the cross by himself he went out to what is called the Place of the Skull, which in Hebrew is called Golgotha. **There they crucified him** and with him two others, one on either side, with Jesus between them. Pilate also had an inscription written and put on the cross. It read, "Jesus of Nazareth, the King of the Jews." Many of the Jews read this inscription because the place where Jesus was crucified was near the city, and it was written in Hebrew, in Latin, and in Greek. Then the chief priests of the Jews said to Pilate, "Do not write, 'The King of the Jews,' but, 'This man said, I am King of the Jews.'" Pilate answered, "What I have written I have written." When the soldiers had crucified Jesus, they took his clothes and divided them into four parts, one for each soldier. They also took his tunic; now the tunic was seamless, woven in one piece from the top. So they said to one another, "Let us not tear it but cast lots for it to see who will get it." This was to fulfill what the scripture says,

"They divided my clothes among themselves,
and for my clothing they cast lots."

And that is what the soldiers did.

Meanwhile, standing near the cross of Jesus were his mother, and his mother's sister, Mary the wife of Clopas, and Mary Magdalene.

When Jesus saw his mother and the disciple whom he loved standing beside her, he said to his mother, "Woman, here is your son." Then

he said to the disciple, "Here is your mother." And from that hour the disciple took her into his own home.

After this, when Jesus knew that all was now finished, he said (in order to fulfill the scripture), "I am thirsty." A jar full of sour wine was standing there. So they put a sponge full of the wine on a branch of hyssop and held it to his mouth. When Jesus had received the wine, he said, "It is finished."

Then he bowed his head and gave up his spirit.

Since it was the day of Preparation, the Jews did not want the bodies left on the cross during the Sabbath, especially because that Sabbath was a day of great solemnity. So they asked Pilate to have the legs of the crucified men broken and the bodies removed. Then the soldiers came and broke the legs of the first and of the other who had been crucified with him. But when they came to Jesus and saw that he was already dead, they did not break his legs. Instead, one of the soldiers pierced his side with a spear, and at once blood and water came out. (He who saw this has testified so that you also may believe.

Brother, sister, let me serve you (*StF* 611)

Eat this bread and never hunger (*StF* 582)

God give us life when all around spells death (*StF* 612)

Guide me, O thou great Jehovah (*StF* 465)

His testimony is true, and he knows that he tells the truth, so that you also may continue to believe.) These things occurred so that the scripture might be fulfilled, "None of his bones shall be broken." And again another passage of scripture says, "They will look on the one whom they have pierced."

After these things, Joseph of Arimathea, who was a disciple of Jesus, though a secret one because of his fear of the Jews, asked Pilate to let him take away the body of Jesus. Pilate gave him permission, so he came and removed his body. Nicodemus, who had at first come to Jesus by night, also came, bringing a **mixture of myrrh and aloes, weighing about a hundred pounds**. They took the body of Jesus and wrapped it with the spices in linen cloths, according to the burial custom of the Jews. Now there was a garden in the place where he was crucified, and in the garden there was a new tomb in which no one had ever been laid. And so, because it was the Jewish day of Preparation and the tomb was nearby, they laid Jesus there.

Songs and hymns

Mijn God, mijn God, waarom verlaat U mij ("My God, my God, why have you left me here?") Klaus Heoroma, *God Welcomes All Hymns Ancient and Modern* #2

Opening liturgy

Remove everything from the Lenten cross.

Give us this day our daily bread to face the sorrows of our soul...

To face the pain, the anguish, the agony,
the injustice, the violence of the world around us.

Give us this day our daily bread that to face the sorrows of our soul...

To face the love and the hate, that bring tears to our eyes,
to face the confusions that leave empty hollowness.

Give us this day our daily bread that to face the sorrows of our soul...

To hold fast to our faith in a world that tries to strip us of worth and value,
to live with our faith, our belief despite all around us.

O Lord our God, on this Lenten journey,

let us face our sorrow, feel our sorrow and trust your Word. Amen.

Background notes

There they crucified him...

The Gospels give few details about Jesus's crucifixion, simply noting it occurred.

Meanwhile, standing near the cross of Jesus were his mother, and his mother's sister, Mary the wife of Clopas, and Mary Magdalene.

A community united by love gathers at the cross, a sign of hope and new relationship for all.¹ Jesus instructs his mother and "the disciple whom he loved" to treat each other as mother and son. Family is not always defined by blood relationship.

...a mixture of myrrh and aloes, weighing about a hundred pounds...

Jesus' burial is wildly abundant: Joseph of Arimathea and Nicodemus bring an extravagant amount of spices, a hundred times more than Mary used earlier – a burial fit for a king.² Joseph and Nicodemus were surprising people to do this; both perhaps can be classed as 'secret disciples.'³

1 Ford, pp. 378-381.

2 Ford, pp. 392-393.

3 Craig Keener. *The Gospel of John: A Commentary* (2003) Baker Academic, Grand Rapids pp. 1158-1162.

Questions for discussion

Here are some discussion questions based on the themes in this passage. These questions prompt reflection on themes of sacrifice, the power of presence and the expressions of love and devotion in the face of grief and loss.

- **“There they crucified him...”** The Gospels offer few details about the crucifixion itself. Why do you think this is? How does this simplicity affect the way we reflect on Jesus’ suffering and sacrifice?
- **A community of love at the cross** In John’s Gospel, Jesus’ mother and several others stand at the foot of the cross. What might it have meant for them to be present at such a painful moment? How does this image of a loving community gathered in suffering encourage us in times of hardship?
- **A wildly abundant burial** Joseph of Arimathea and Nicodemus buried Jesus as a King, revealing something about what he meant to them. What does Jesus’ death mean to you? How might you, a humble disciple like Joseph or Nicodemus, show others what Jesus means to you, today?

Prayer ideas

The service for Good Friday in the *Methodist Worship Book* (pp. 255ff) contains appropriate prayers.

The good news to get across

Even in the most challenging times, we can draw strength and resilience from both those close to us and from strangers. Their support and kindness can provide encouragement and hope, reminding us that we are never truly alone in our struggles.

Ways people can respond

The traditional end of the Good Friday service involves people leaving in silence, without saying goodbye. Invite participants to reflect on the experience of this silent departure and the sense of solidarity and mutual support that exists within the congregation, achieved without the need for audible communication.

Prayer of blessing

May the God, who suffered pain beyond our comprehension,
grant that your soul is supported through the hardest times.

Amen.

Sunday 20 April 2025

Easter Day: Soul Stories

So well nourished that we have to share it

Bible readings

Psalm 118:1-2, 14-24

O give thanks to the LORD, for he is good;
his steadfast love endures forever!

Let Israel say,

“His steadfast love endures forever.”

The LORD is my strength and my might;
he has become my salvation.

There are glad songs of victory in the tents of
the righteous:

“The right hand of the LORD does valiantly;
the right hand of the LORD is exalted;
the right hand of the LORD does valiantly.”

I shall not die, but I shall live

and recount the deeds of the LORD.

The LORD has punished me severely,
but he did not give me over to death.

Open to me the gates of righteousness,
that I may enter through them
and give thanks to the LORD.

This is the gate of the LORD;
the righteous shall enter through it.

I thank you that you have answered me
and have become my salvation.

The stone that the builders rejected
has become the chief cornerstone.

This is the LORD’s doing;
it is marvellous in our eyes.

This is the day that the LORD has made;
let us rejoice and be glad in it.

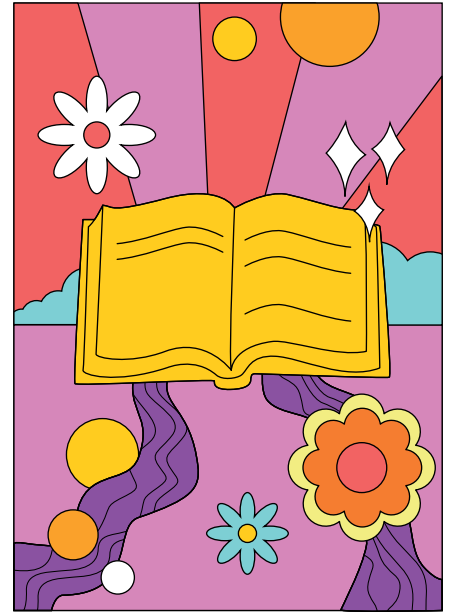

Luke 24:1-12

But on the first day of the week, at early dawn, they went to the tomb, taking the spices that they had prepared. They found the stone rolled away from the tomb, but when they went in they did not find the body. While they were perplexed about this, suddenly two men in dazzling clothes stood beside them. The women were terrified and bowed their faces to the ground, but the men said to them, “**Why do you look for the living among the dead?** He is not here but has risen. Remember how he told you, while he was still in Galilee, that the Son of Man must be handed over to the hands of sinners and be crucified and on the third day rise again.” Then they remembered his words, and returning from the tomb **they told all this to the eleven and to all the rest.** Now it was **Mary Magdalene, Joanna, Mary the mother of James, and the other women with them** who told this to the apostles. But these words seemed to them **an idle tale**, and they did not believe them. But Peter got up and ran to the tomb; stooping and looking in, he saw the linen cloths by themselves; then he went home, amazed at what had happened.

Songs and hymns

Come, let us anew our journey pursue
(StF 460)

Jesus the Lord said: "I am the bread"
(StF 252) esp v5

May the God of hope go with us every day
(StF 411)

Now let us from this table rise (StF 596)

Praise and thanksgiving, Father we offer
(StF 125)

Teach me to dance to the beat of your
heart (StF 477)

Tell out, my soul, the greatness of the Lord!
(StF 186)

We have a gospel to proclaim (StF 418)

Opening liturgy

Return every object from Lent to the cross.

Alleluia, Alleluia! is our story and our song
*Give us this day our daily bread that our cup
overflows with enough to share...*

That our souls proclaim the greatness
of the Lord,

that our souls overflow with a story to tell.

*Give us this day our daily bread that our cup
overflows with enough to share...*

With words and gifts and smiles and songs,
with Hallelujahs echoing from our souls.

*Give us this day our daily bread that our cup
overflows with enough to share...*

That we may sit and stand and walk as stories
are shared and truths revealed,

that we may listen and hear and speak and
sing and shout.

O Lord our God, our Lenten journey has ended,
our Easter journey begun.

**Nourished by our journey, let us share and tell
your living, loving stories, we pray.**

Alleluia, Alleluia for Christ is risen, Alleluia!

Object

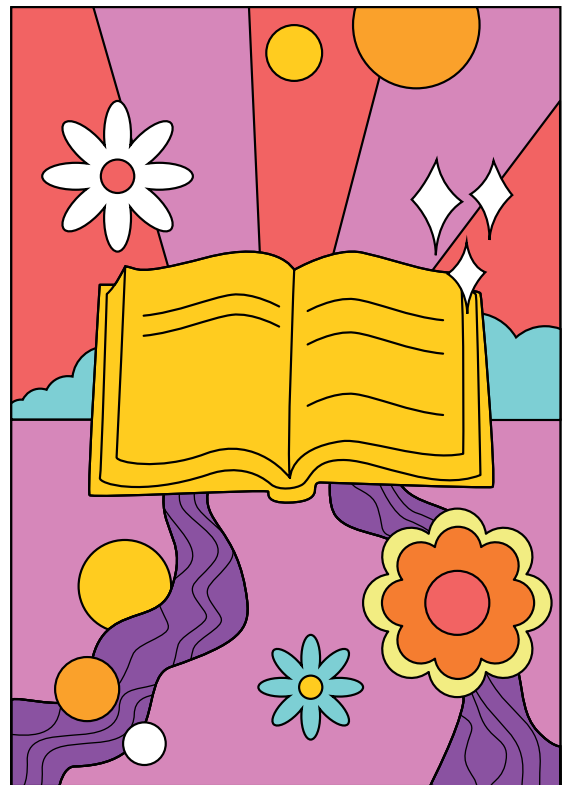

An open story book

Background notes

Why do you look for the living among the dead?

Only Luke includes this specific question, replacing the assurance offered to the women in Mark and Matthew. Luke frequently uses the concept of the risen Jesus being alive (see Luke 24:23, Acts 1:3, Acts 3:15) as a powerful way to affirm the truth of the Resurrection.¹

...they told all this to the eleven and to all the rest.

This group of women reflected on their memories of Jesus' words in light of the astonishing Resurrection event. They spontaneously left to share the news; not only with the eleven remaining (male) disciples but also with "all the rest". These women were the Resurrection witnesses.

Mary Magdalene, Joanna, Mary the mother of James, and the other women with them...

The women present at the crucifixion, burial and Resurrection of Jesus are finally named. Mary Magdalene and Joanna are mentioned earlier in Luke (8:1-3) as part of the group of women who accompanied Jesus during his ministry in Galilee and supported him financially. The reference to "Mary the mother of James" is unlikely to denote Jesus' mother, as Luke explicitly names her in Acts 1:14.

...an idle tale...

Unfortunately, the women's testimony about the Resurrection wasn't believed by the apostles, who dismissed it and ridiculed them. One way to understand this is that it might emphasise just how astonishing the Resurrection was – even Jesus's closest followers couldn't initially accept it, despite the women's witness.² This perspective might also help us empathise with people today who remain unmoved by the evidence for God that has convinced us.

Questions for discussion

Here are some discussion questions based on the Resurrection story, focusing on themes of witness, belief and the role of women in sharing the good news. These questions encourage reflection on how we encounter the risen Jesus, the importance of inclusivity in sharing the gospel, and the resilience needed to testify to God's work, even in the face of doubt.

- **The risen Jesus as "alive"** Luke often emphasises that Jesus is "alive" following the Resurrection. How does this word "alive" resonate differently from simply being "raised"? What does it mean for us today to follow a "living" Jesus?
- **Women as witnesses** In Luke's Gospel, the women are the first to witness and proclaim the Resurrection. How does their role in sharing the news impact the way we view women's voices in faith communities today? How does their resilience inspire us in sharing our faith?

1 Fitzmeyer, p. 1545.

2 Evans, p. 898.

- **The power of witnessing:** The women's testimonies were dismissed as 'idle tales' when in fact they were full of the truth of their experience. We can be tempted to spend our days speaking of 'idle' things – like the weather! – but real talk about the deepest aspects of our lives has the power to connect us and change us. Tell one another about a powerful encounter with God you've had. How does this experience of speaking and listening change you as a group?

Prayer ideas

Have a short conversation with the person next to you about what is on your heart this day, and pray for each other.

The good news to get across



Jesus is alive and death has been defeated! Let us follow the example of the women who first proclaimed this good news, sharing the message with those who need to hear it. Together, we can spread hope and joy, transforming lives through the power of the Resurrection.

Ways people can respond

Invite people to look for opportunities to have conversations with people who do not go to church about how the truth that Jesus is alive changes their life every day.

You may decide to run the 'Everyone an Evangelist' course in your community as a next step, to give people the confidence and tools that they need.

Hands-on activities

Make hero-style puppet figures of the women witnesses: Mary Magdalene, Mary mother of James, and Joanna. You could also make a little scene of the garden tomb to place them in. There is a printable template to colour and cut out at methodist.org.uk/SoulFood

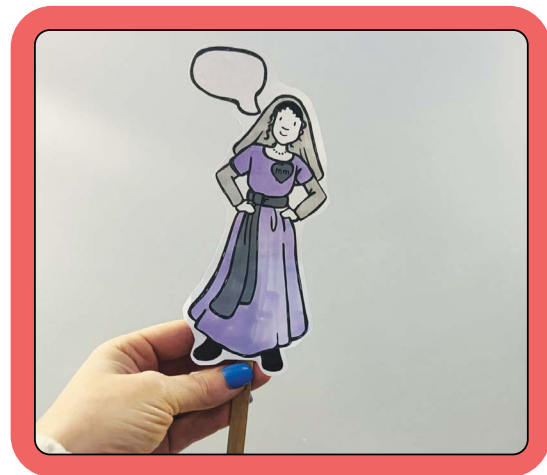
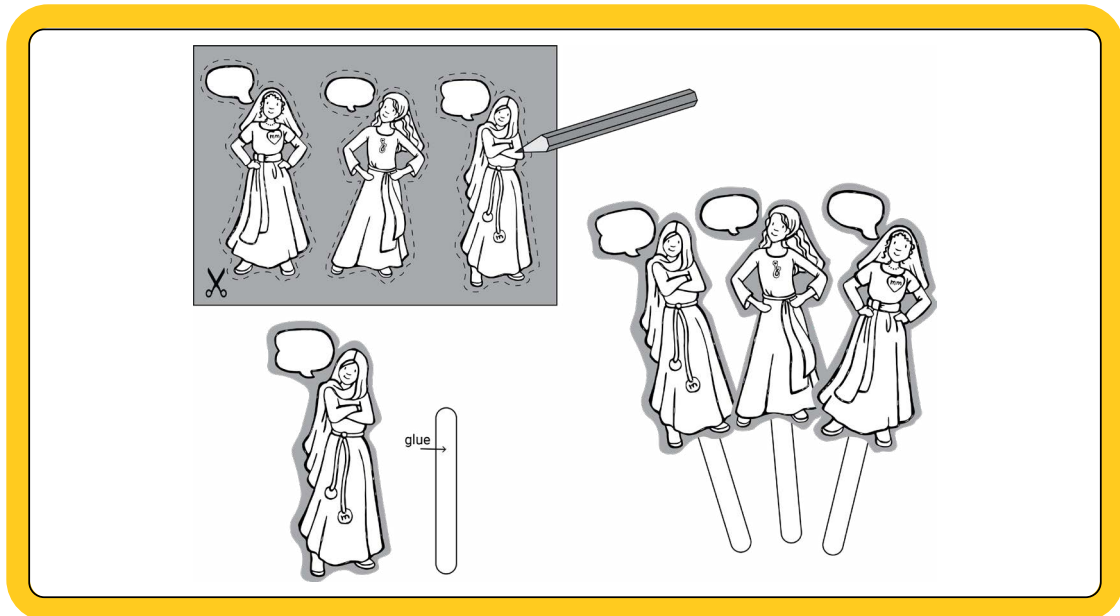

Prayer of blessing

May the living God so fill your hearts with joy and hope
that you cannot keep the good news to yourself.

In the name of Christ, Alleluia!

All Bible quotations taken from the *New Revised Standard Version, Updated Edition*.
Copyright © 2021 National Council of Churches of Christ in the United States of America. Used by
permission. All rights reserved worldwide.

If you would like to request this resource in an alternative format, please contact us to discuss your needs at
publishing@methodistchurch.org.uk

Published by the Methodist Church in Great Britain. Registered charity number 1132208
© Trustees for Methodist Church Purposes 2025